

WT-5LCV Rewind System

910 BOLGER COURT. FENTON, MO 63026. USA
(800) 325-9777 (636) 343-0806 FAX: (636) 343-6629
sales@webtechniquesinc.com | webtechniquesinc.com



SOLVE YOUR LABEL INVENTORY ISSUES WITH A WEB TECHNIQUES REWIND SYSTEM

SAVE MONEY AND TIME BY QUICKLY AND ACCURATELY COUNTING AND REWINDING YOUR LABELS WITH A WEB TECHNIQUES REWIND SYSTEM.

- 1. FAST, EASY TO USE**
- 2. REQUIRES PRACTICALLY NO SET-UP TIME**
- 3. QUICKLY REWINDS LARGE MASTER ROLLS INTO ROLLS OF PREDETERMINED COUNT**

FEATURES:

1. **INFINITELY VARIABLE MOTOR SPEED CONTROL**
Variable speed control allows high speed rewinding with low speed control.
2. **CENTRALLY LOCATED, BACKLIT TOUCH SCREEN CONTROL**
Dual Preset: Set one point for deceleration and a second point for final stop
Counts in both English or Metric Units at the touch of a button
3. **WIND LABELS AND/OR TAPE IN OR OUT**
CONTACT US REGARDING YOUR MATERIAL ON A ROLL FOR EVALUATION.
4. **STAINLESS STEEL REWIND SURFACE**
5. **STANDARD 10", 12" COUNTS OR METRIC INCREMENTS, COUNT INCREMENT ADJUSTABLE FROM 0.1" – 99" MEASUREMENTS**
6. **COUNT ALL LABEL TYPES (PAPER AND CLEAR)**
7. **FLANGE MOUNTED AIR COREHOLDERS**

9. **CHOICE OF COREHOLDER SIZES**
Coreholders range in size from coreless to 0.4" through 6" (25mm through 120mm), Please do not hesitate to contact us with any special requests
10. **TABLE TOP SYSTEM**
Small footprint (18" X 17" footprint) allows for precise industrial rewinding in a small package.
11. **REWIND UP TO 12" DIAMETER 7" WIDE ROLLS**
Rewind rolls weighing 30+ pounds.

WT-5LCV System Specifications:

Web Width (MAX): 7"
Unwind Roll (MAX): 12"
Rewind Roll (MAX): 12"
Roll Weight (MAX): 30 lbs.
Rewind Speed (MAX): 1,200 ft/min
Tension Brake: Standard/Pneumatic Brake is Optional
AC Motor: 1HP
Decel & Stop: Standard/Included
Winding: CW & CCW
Rewind Stop Type: Deceleration/Friction
Count Methods: Length & Label
Electrical: 120VAC Standard/ 220VAC Optional

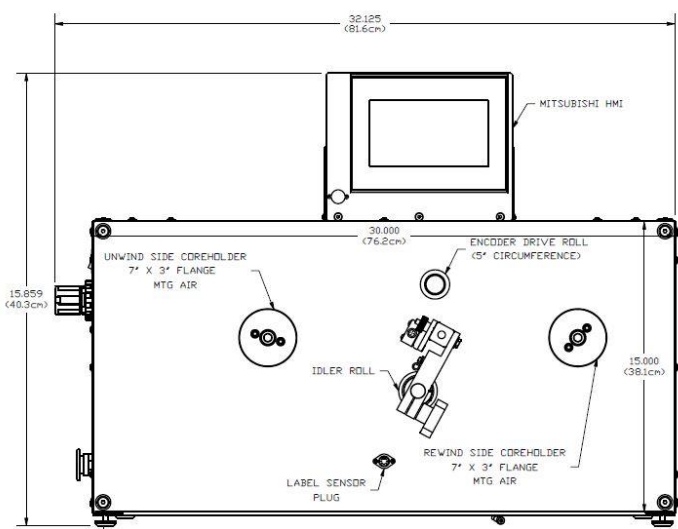
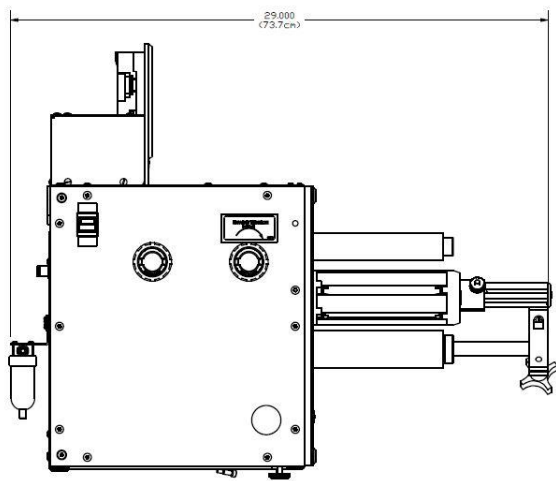

WEB PATH ILLUSTRATION

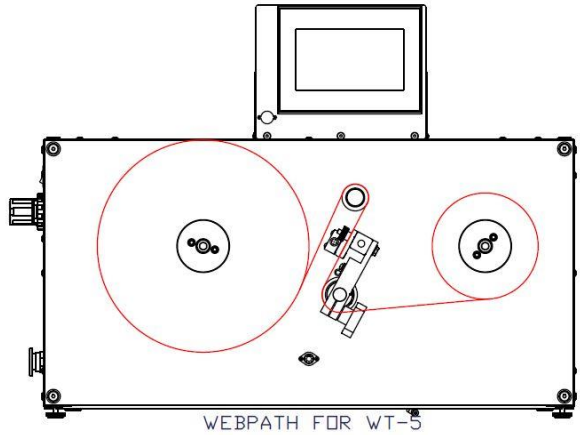

910 BOLGER COURT. FENTON, MO 63026 . USA
(800) 325-9777 (636) 343-0806 FAX: (636) 343-6629